

LOCAL EXTRACTOR

TEX **2000** **with gas spring**

Telescopic local extractor suitable for confined spaces, e.g. welding booths and workbenches.

The MOVEX local extractor TEX, with the length 7 feet, is a telescopic local extractor for e.g. welding worksites where a compact local extractor with low pressure drop is required. In addition to the telescopic function, the TEX is also equipped with a gas spring that balances the dead weight of the arm. The suction nozzle with a manually operated damper incorporates a swivel function. It may be rotated 360° and moved to a 90° angle.

MOVEX always designs its local extractors with supporting brackets on the outside, which ensures a natural and undisturbed air flow. In addition, the pressure drop will be low and there is hardly any risk of ducts being blocked. The TEX may also be equipped with a flat screen hood for even greater efficiency. A conical hood, with or without halogen light, is also available.

The smooth inside of the suction duct makes the TEX very easy to clean. Adjustments of joints as well as maintenance can easily be taken care of with hand tools from the outside.

The MOVEX TEX is easy to install and can be delivered with brackets for ceiling or floor mounting.



White design



Suction nozzle with damper and 360° swivel

Movex also offers a range of fans, accessories and automatic control devices for our local extractors.

MOVEX[®]
LOCAL EXTRACTOR
Pure advantage

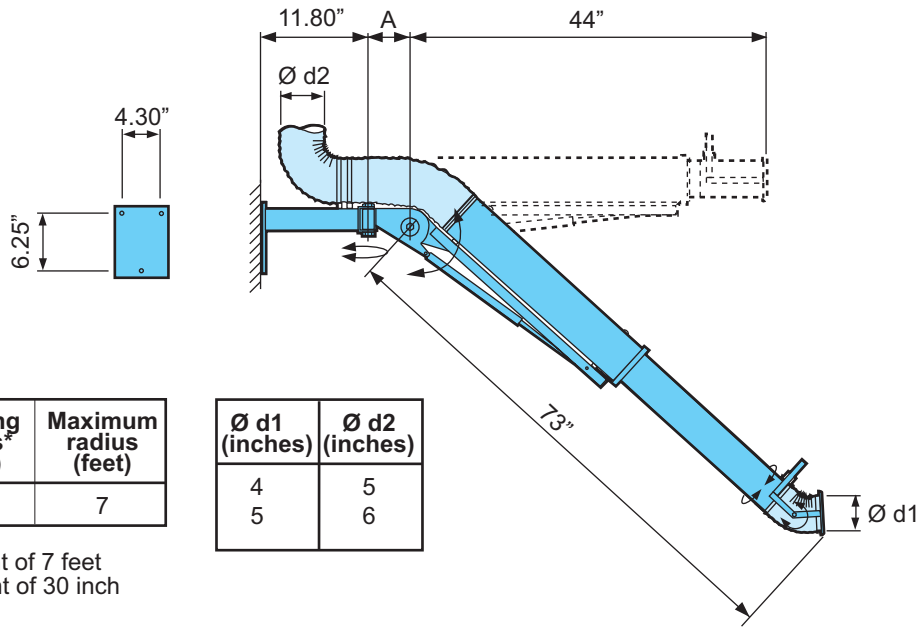

	Working radius* (feet)	Maximum radius (feet)
TEX-2000	6	7

Ø d1 (inches)	Ø d2 (inches)
4	5
5	6

* At a mounting height of 7 feet and a working height of 30 inch

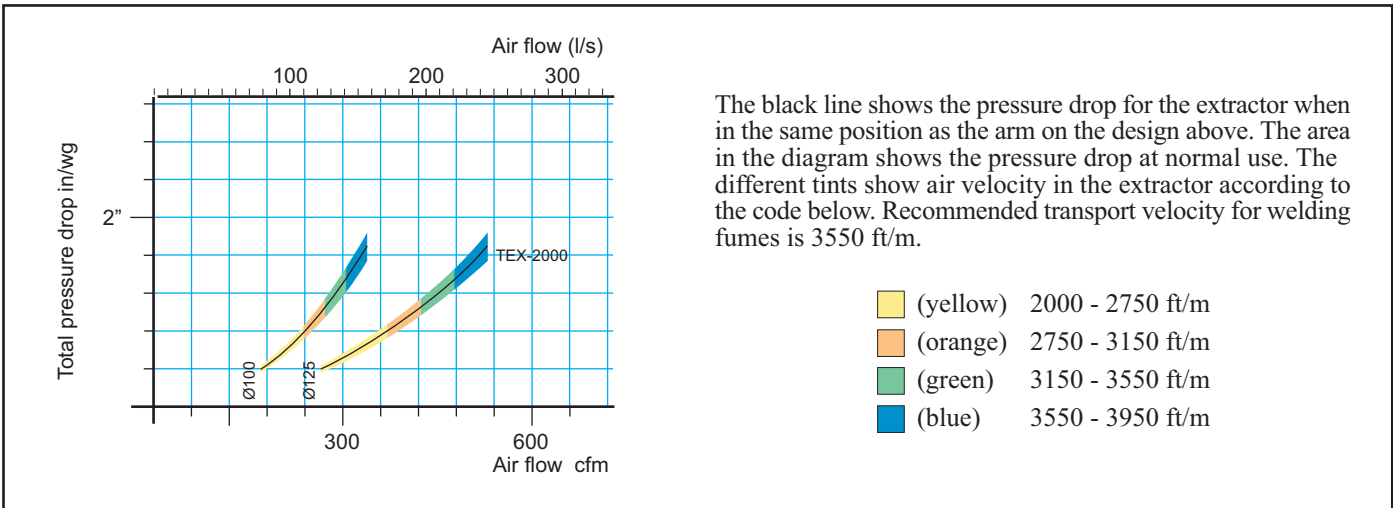

The black line shows the pressure drop for the extractor when in the same position as the arm on the design above. The area in the diagram shows the pressure drop at normal use. The different tints show air velocity in the extractor according to the code below. Recommended transport velocity for welding fumes is 3550 ft/m.

Hose

Made of spring steel coil completely embedded in PVC-coated polyamide fabric.
For other hose qualities, contact us.

Tube

Made of powder coated, rounded sheet steel.

Sliding lining

Material: PEHD-300, adjustable friction

Delivery

For easy installation, the arm is delivered fully assembled including bracket for wall mounting. The arm can also be delivered in white coating and tubes in stainless steel. Accessories include brackets for ceiling, floor and table mounting and flat screen hood or conical hood with or without halogen light.

Hose

Qualities Non flammable, suitable for welding fumes and flue gas.
Temperature range 14°F to 194°F

Sliding lining

Temperature range 14°F to 176°F

Other information

Surface treatment of metal components Powder coating
Weight 30 lb

MOVEX® INC.
104 Commerce Drive, Suit C,
Northampton, PA 18067, USA
Tel: 610-440-0478 Fax: 610-440-0480
www.movexinc.com e-mail: info@movexinc.com

Dealer: